

NEW API STANDARD 618 (5TH ED.) AND ITS IMPACT ON RECIPROCATING COMPRESSOR PACKAGE DESIGN

API 618 5th Edition (the Standard) Only Specifies Minimum Requirements — More Aggressive and Innovative Approaches Can Realize Significant Savings

By Shelley Greenfield, P.E. and Kelly Eberle

Editor's Note: *The new API Standard 618 (5th Edition) affects how packagers and owners design reciprocating compressor packages to avoid pulsation- and vibration-related problems.*

Shelley Greenfield is vice president of Engineering Design Services at Beta Machinery Analysis, Calgary, Alberta, Canada. She leads the company's design teams, structural, foundation and skid design services, customer support and training initiatives. This includes managing relationships with Beta's customers, OEMs and packagers in Asia, Europe and North/South America. Greenfield has 23 years of direct experience in performing API 618-related design studies and actively participated on the API 618 Standard 5th edition pulsation task force. She has published technical articles and presented at various technical conferences in North America and Europe. She received a BSc degree (Mechanical Engineering) from the University of Calgary and is a Professional Engineer. Kelly Eberle is a principal engineer at Beta with over 20 years of design and field experience, particularly in the area of pressure pulsation analysis and mechanical analysis of reciprocating compressor and pump installations, and structural analysis for offshore projects. The scope of his design experience includes acoustical simulations, thermal flexibility studies, static and dynamic finite element analyses, structural analysis and foundation analysis. He directs Beta's Research and Development group focusing on new analysis tools and techniques. Eberle has published technical articles and presented at the GMRC, EFRC and The Vibration Institute. He received his BSc degree in Mechanical Engineering from the University of Saskatchewan.

Changes to Pulsation, Vibration, Torsional, Skid, Engineering Studies

Summary of API Standard 618 and Key Changes in the 5th Edition — API Standard 618 (the Standard) is the recognized specification for owners and manufacturers of reciprocating compressors. The 4th Edition of API 618 was published in 1995. During the following 12 years, the industry identified many enhancements to this Standard, which were included in the new 5th Edition, published in December 2007. The Standard can be purchased on online at <http://www.IHS.com>.

A key section of the Standard focuses on the design to control pulsation and vibration for reciprocating compressor systems, section 7.9. This section of the Standard is used throughout the industry, including high-speed machines.

The purpose of API 618 is to establish minimum design requirements. Later, in this presentation, API recommends that the user and manufacturer go beyond these minimum standards and “aggressively pursue” designs that improve efficiency and minimize “total life-cycle costs (as opposed to acquisition cost alone).”

The following points summarize key changes incorporated in the 5th Edition.

Pulsation Analysis: For cases where the piping design is not available, the pulsation supplier can perform a “pre-study,” or damper check, to calculate bottle sizes. Suppliers should be aware of consequences to this approach (see below). Unbalanced force guidelines for piping and vessels are defined.

Line side pulsation guideline has been updated to account for the specific speed of sound of the gas (now allows for higher pulsations in low-density gas and lower pulsations in high-density gas).

Allowable pressure drop criterion now includes a guideline for dynamic pressure drop as well as steady-state pressure drop.

The pulsation analysis must consider the full range of conditions including different gas analysis, all planned operating conditions and load steps.

If multiple units are connected together through a common piping system, then a multi-unit analysis is required to ensure the cumulative pulsation effects are addressed and comply with standard.

Vibration Control: To avoid resonance and excessive vibration, mechanical analysis of the compressor package is needed to recommend modifications to the piping system.

The forced response (formerly known as M6 and M7) studies are no longer required on all Design Approach 3 (DA3) projects. These studies are only required if the pulsation and mechanical design do not meet the required guidelines. In addition, more specific instructions are provided on how these studies should be performed to ensure accurate results.

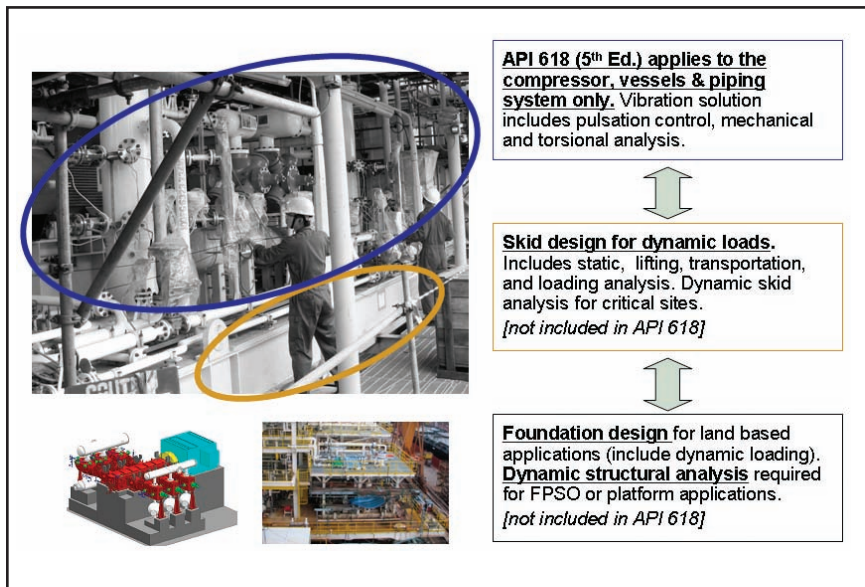

more system parameters that affect pulsation and vibration². The definition of the design approaches in the new 5th Edition is similar to the 4th Edition but with some important differences. The 5th Edition includes a description of the design criteria and the necessary steps required to meet the various Design Approaches. The revised Standard includes several flow charts to describe these steps and Design Approaches, which are complicated and can be difficult to interpret. Following is a simplified description of the Design Approaches and analysis steps.

Design Approach 1 (DA1, also Step 1): The scope includes basic bottle sizing using empirical calculation. This does not include pulsation study (consistent with 4th Edition).

Design Approach 2 (DA2, also Step 2): The scope includes pulsation control design in conjunction with a mechanical review (basic vessel calculations and review pipe runs and anchoring system). Pulsations are to be analyzed with acoustic simulation to assess pulsation, forces and pressure drop. The DA2 scope does not include mechanical modeling to calculate MNFs.

The following simplified flow chart identifies two ways to design the pulsation solution. The recommended approach provides a more reliable, efficient and lowest overall pulsation control solution (compared with optional approach, discussed below), but requires piping layout information.

The optional approach can be undertaken if bottles must be ordered before the piping system is defined. Initial bottle sizes are based on a pre-study, or damper check. This is an acoustical simulation of the gas passages and bottles based on a line connection with infinite length. The drawback with this approach is that the packager/owner will have difficulty optimizing the pulsation control solution once the final piping system is determined; pressure drop may be higher, bottles may need to be redesigned, and additional pulsation analysis may be needed at a later date to determine support requirements.

Design Approach 3 (DA3): The scope includes Step 2: Pulsation analysis (per DA2 above) plus:

Step 3a. Accurate Modeling of MNFs. Analyze compressor and piping system to avoid mechanical resonances at frequencies where significant shaking forces exist. This

The former M8 study (stress analysis of the bottle internals) is optional and is to be done only if specified by the owner.

The margin of separation between the Mechanical Natural Frequency (MNF) and shaking force, or excitation, frequency is $\pm 20\%$. In addition, the minimum MNF must be greater than 2.4 times maximum run speed.

Vibration design guidelines have been added.

The owner and packager are encouraged to exceed these standards to improve efficiency and reduce total life-cycle costs. We refer to this as optimized design practices.

Pulsation and Vibration Control (section 7.9 of the Standard): — There are three design approaches for pulsation and vibration control, which is consistent with the 4th Edition. The new 5th Edition of the Standard no longer uses “M study” terminology to designate the separate study components (e.g., M2 for pulsation study, M3 for performance analysis).

The following application selection chart (see below) is now included. The recommended design approach (DA) is based on the compressor discharge pressure and rated power per cylinder.

Selection Chart: For Pulsation/Vibration Study Scope (note: DA1 = Design Approach 1, DA2 = Design Approach 2, DA3 = Design Approach 3)

A more detailed application selection chart, Beta’s Risk Rating chart¹, has been developed to incorporate even

step was formerly known as M5 study of compressor manifold. The design shall meet two key parameters:

1. *Separation Margin* between MNF and the shaking force or excitation, frequency. Minimum MNF of any element in the system > 2.4 maximum run speed and predicted MNF shall be separated from significant excitation frequencies by $\pm 20\%$.

2. *Acoustic Shaking Forces* shall not exceed the limits based upon the calculated effective static stiffness and the

Absolute Discharge Pressure	Rated Power per Cylinder		
	kW/cyl < 55 (hp/cyl < 75)	55 < kW/cyl < 220 (75 < hp/cyl < 300)	220 < kW/cyl (300 < hp/Cyl)
P < 35 bar (P < 500 psi)	DA1	DA2	DA2
35 bar < P < 70 bar (500 psi < P < 1000 psi)	DA2	DA2	DA3
70 bar < P < 200 bar (1000 psi < P < 3000 psi)	DA2	DA3	DA3
200 bar < P < 350 bar (3000 psi < P < 5000 psi)	DA3	DA3	DA3

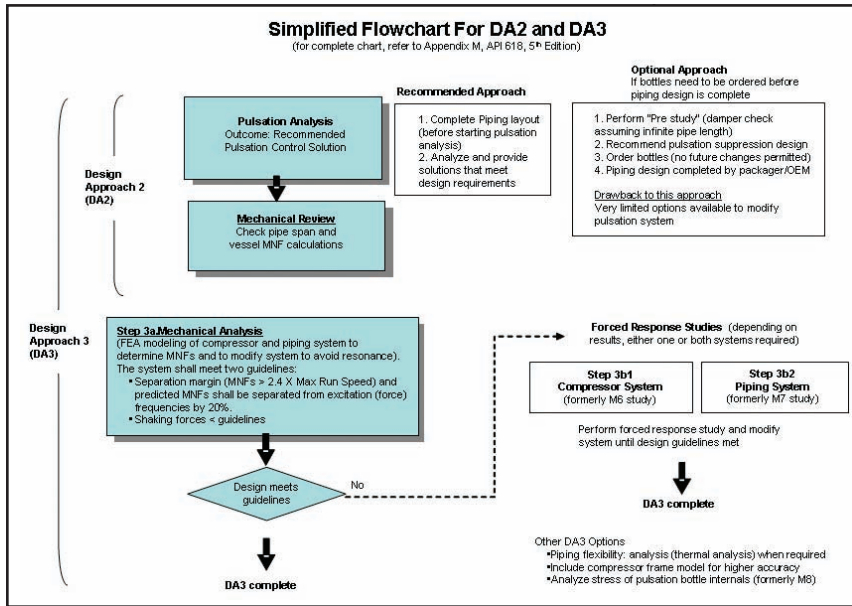

generally limited to specific areas where the forces exceed the guideline, or the mechanical design criteria cannot be met.

Based on the writers' experience this study is seldom required for standard compressor packages.

There is a benefit to the packager or owner for conducting this analysis in specific cases, such as:

- New installations where bottle material has been purchased.
- Existing installations where making pipe layout, or support changes, are difficult.
- Design optimization studies where analyses have competing requirements. A typical example is the elevated piping around air coolers. The hot discharge piping requires a flexible design to minimize nozzle loads, but the mechanical requirements for minimum vibration requires a stiff design.

design vibration guideline. API 618 defines a method for estimating the effective stiffness of the piping and the bottle without conducting comprehensive mechanical modeling.

If design guidelines for Steps 2 and 3a are met, API 618 DA3 is complete. If any of the guidelines are not met, Steps 3b(1) and/or 3b(2) will be required to meet DA3 requirements.

Forced response analysis may be required (contingent on Step 3a results)

- **Step 3b(1). Compressor Mechanical Model Analysis (formerly called M6 study)**

This step applies to the pulsation suppression devices (bottles). If the separation margin or shaking force criteria in Step 3a, above, cannot be met, a forced response analysis of the compressor mechanical model must be conducted. The analysis is to include the *pulsation shaking forces* and *cylinder gas forces*. The design must meet the allowable cyclic stress criteria.

Note: The cylinder gas forces (also called frame stretch, or cylinder stretch forces) can cause excessive pulsation bottle vibrations even if the pulsation shaking forces meet the Standard. API 618 5th Edition does not provide any guidelines for acceptable cylinder gas forces. Based on the writers' experience, the Compressor Mechanical Model Analysis in Step 3b(1) is required for medium to high speed units when:

- HP/cylinder >750 or rod loads exceed 80% rated rod load.
- Wide speed range operation is required (more than 25% of rated).
- Compression ratio is below 1.7.
- Compressor is in a critical application.

- **Step 3b(2). Piping System Analysis (formerly called M7 study)**

If the Separation margin, or shaking force criteria in Step 3a, above, cannot be met, a forced response analysis of the piping system to pulsation shaking forces must be done.

The design must meet the allowable cyclic stress criteria and vibration limits. Piping system may include all piping included in the pulsation (acoustic) analysis, but is

Torsional Vibration Analysis (TVA)

The new 5th Edition states:

"The compressor vendor shall perform the necessary lateral and torsional studies to demonstrate the elimination of any lateral or torsional vibrations that may hinder the operation of the complete unit within the specified operating speed range in any specified loading step."

Typically, lateral critical studies are not required for reciprocating compressor applications. Lateral natural frequencies will be positioned well above significant torsional natural frequencies, or any forcing frequencies generated by the compressor or driving equipment.

The new 5th Edition also states:

"The compressor vendor shall provide a torsional analysis of all machines furnished (except small belt units). The study shall eliminate any harmful lateral or torsional vibrations for all specified speed ranges and loading steps."

A stress analysis shall be performed if the torsional resonance falls close to the torsional natural frequency. The stress analysis is to ensure that the resonance will not be harmful for the compressor system.

The TVA report includes data used in mass elastic system, display of forces vs. speed (and frequency), torsional critical speed and deflections (mode shape diagram), worst-case design and upset condition results including failed compressor valves, engine misfire and worn damper cases. The report should also consider how the input data variance will affect the results.

Dynamic Skid Analysis

The dynamic skid study (including forced response analysis) is outlined in section 7.5.4.14 of the Standard, and is strongly recommended for packages mounted on offshore platforms or modules mounted on steel columns.

At Beta Machinery Analysis, we recommend that a dynamic skid analysis is also conducted for,

- new or unproven skid designs;
- two throw, high-speed, variable speed compressors; and
- skids mounted on concrete foundations (and gravel pads) where the local soil conditions are suspect.

Although not part of API 618, a skid lifting study, transit study, and environmental loading analysis, are often required. Beta recommends that the same party conduct all skid studies.

Implications for Foundation Design or Platform/FPSO Structures

While not addressed in this Standard, the assumption is that the owner has specified a foundation design including dynamic analysis of shaking forces and the interaction of loading on the gravel, pile or concrete foundation. For offshore production platforms or FPSOs, the dynamic analysis of the compressor, skid and structure becomes even more important. Dynamic analysis of reciprocating compressor foundations requires specialized knowledge, experience and simulation tools. The party chosen to conduct the foundation design must be carefully selected.

The accuracy of the dynamic skid analysis is strongly influenced by the design of the foundation for offshore installations or onshore pile installations. The dynamic skid analysis must include modeling and simulation of the foundation at the same time. Separate dynamic analysis of the skid and foundation cannot be done accurately.³

Piping Flexibility (Thermal) Analysis

Sections 7.9.4.2.3.6 and 7.9.4.2.5.2.5.2 of the Standard refer to the piping system design, including the effect of piping movements due to temperature changes as well as weight, pressure and other factors. The thermal design often requires that flexibility be added to the system. This requirement is counter to the requirement for more support (increased stiffness) to meet the MNF design required. It is recommended that the same party conducting the DA2 or DA3 study to control vibration, also conduct the piping flexibility study. The purpose of this is to minimize design iterations and result in an overall optimized design.

The Thermal Analysis (formerly M11 study) is specified as optional in the 5th Edition. Beta recommends this analysis be conducted to the compressor package when the cooler is off-skid, when there are multiple compressor packages on a common header, when the installation will experience extremely cold ambient temperatures, or for compressors that operate over a very wide range of conditions (one-stage or two-stage operation).

Summary

The new API 618 5th Edition includes many improvements over the 4th Edition in the specification for engineering studies to minimize pulsation and vibration. These new specifications have an impact on packagers and owners. Also, the revised Standard has some areas in the specification that require interpretation by engineering service providers.

Part II of this article expands on some of these impacts to users and packagers.

Footnotes

¹ Find Beta's Risk Rating Chart on our website (www.BetaMachinery.com > Support > Risk Rating Chart and Specification Guide).

² Beta's Application Note #2 also provides guidelines to help decide which study scope is recommended. (see www.BetaMachinery.com > Support > Application Notes).

³ For more information on dynamic analysis for offshore structures, such as FPSO, refer to the article, "Dynamic Analysis of Reciprocating Compressors on FPSO Topsides Modules," which was delivered at the 5th European Forum for Reciprocating Compressors Conference in 2007. The article, reprinted from **COMPRESSORTech™** magazine, is a free

download from our website (www.betamachinery.com > Support > Articles).

Implications of the New API 618 (5th Edition) for Packagers, OEMs and Owners

Overview of medium or large horsepower reciprocating compressor systems typically requires a pulsation and vibration design study as outlined in API 618 (the Standard) 5th Edition. These studies have proven to mitigate the risk of excessive vibration and avoid costly repair, maintenance and downtime costs. When specifying an API 618 pulsation and vibration study, the packager and owner must be aware of the following four issues:

1. Cylinder stretch force guidelines are mentioned, however, the Standard does not provide any guidelines for acceptable cylinder gas forces. These forces must be assessed in a study since they can be a significant source of excitation at all orders of compressor speed.

2. Mechanical design for medium- and high-speed machines represents challenges in meeting API 618 design specifications. The stiffness of scrubbers and other components needs to be much higher than with slower-speed machines to meet the Mechanical Natural Frequency (MNF) guideline.

3. The vibration study requires accurate models of the mechanical system. Note that the Standard does not specify how to ensure accurate models. Analysis and modeling techniques are, in many areas, left to the engineering service provider. In this section, four key areas are discussed that contribute to poor results and are to be avoided.

4. Reviewing supplier quotations for a Design Approach 3 (DA3) study can be confusing, especially when considering a forced response analysis. This confusion can lead to excessive scope and study costs.

These four issues are discussed and include recommended specifications for purchasing a pulsation and vibration study that ensures reliability (for owners), less warranty costs (for packagers), and a level playing field when quoting on projects (for vibration consultants). Later, Beta Machinery Analysis (Beta) provides suggestions to reduce the total cost and improve efficiency of compressor packages.

Cylinder Stretch Forces Must Be Addressed in the Design

Beta Machinery Analysis (Beta), and other leading experts, has long recognized that the forces acting on the inside of the compressor cylinder are a significant source of excitation at all orders of compressor run speed. These forces cause the compressor cylinder to move away from, and toward, the compressor frame. This motion is commonly called frame stretch or cylinder stretch. See Figure 1.

Cylinder stretch motion can cause high-frequency vibrations on the bottles and piping close to the compressor¹. These forces are mentioned briefly in the 5th Edition of the Standard, but no guidelines are specified. Beta, as well as some other vibration consultants, has developed field-tested guidelines to assess cylinder stretching forces and their potential for causing vibration. During a DA3 study, the vibration consultant will assess the fundamental vibration modes for pulsation bottles at higher orders of compressor speed, and include cylinder stretch forces.

Factors such as power per cylinder, rod load, speed range and others are strong indicators that cylinder stretch-related vibration problems are likely, and that a forced response analysis is warranted (Step 3b1, forced response analysis of the compressor mechanical model).

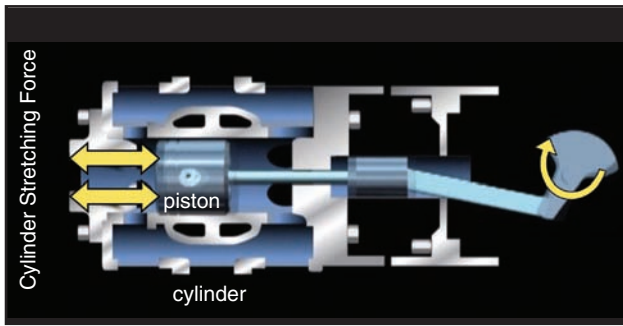

■ Figure 1: Cylinder stretching force is caused by high internal gas forces acting on the inside of the compressor cylinder. These forces can be a significant source of excitation at all orders of compressor run speed.

Mechanical Design to Meet API 618 (5th Edition)

To avoid vibration problems, the vibration consultant adjusts the MNFs of the system to avoid resonance. The 5th Edition includes two specifications relating to component MNFs:

Minimum MNF Guideline — The MNF of bottles, piping and cylinders must be above 2.4 x compressor run speed (Mechanical Design Goal) as shown in Figure 2.

This figure illustrates that the forces in a variable speed unit (red arrows) will occur across a wide frequency range, making it difficult to design a scrubber with an MNF between 1x and 2x run speed. Moving the MNF above 2.4 x run speed will avoid resonance problems.

The Minimum MNF Guideline represents a challenging design requirement for high-speed compressors (1200 to 1800 rpm). In general, the piping or vessels must be much stiffer than in slower-speed units. Early communication between the compressor packager, owner and vibration consultant is necessary to ensure acceptable vessel and skid designs.

Table 1 illustrates the Minimum MNF Guideline for different maximum compressor speeds.

For slow- and medium-speed units, the Minimum MNF Guideline is not a difficult design problem. For high-speed machines, however, the design becomes much more challenging. Table 2 below explains why.

Separation Margin Guideline — The Standard specifies a separation margin of ±20% is required between the calculated MNFs and significant excitation frequencies.

This separation margin requirement can create problems. The term “significant excitation,” that is, a force amplitude, is not defined in the Standard. Also, the “frequencies” to be considered and guidelines for cylinder stretching forces are not defined in the Standard.

Beta’s interpretation of the separation margin guideline is that it applies to frequencies over 2.4 x run speed. The main sources of “significant excitation” are forces from pressure pulsations and the cylinder stretch forces.

The vibration consultant needs to conduct a pulsation analysis to control dynamic forces in the bottles and piping. API has developed force guidelines proven to result in successful designs and controlling vibrations from pulsation forces.

As discussed under “Cylinder Stretch Forces Must be Addressed in the Design,” above, the vibration consultant needs to calculate the cylinder stretch forces as a first step. If the cylinder stretch forces are above a certain level, a compressor mechanical model analysis (*Step 3b1, formerly called M6 study*) is required. The second step in assessing the cylinder stretch forces is evaluating the mode shapes calculated in the mechanical analysis. Certain pulsation bottle mode shapes are known to be very responsive to cylin-

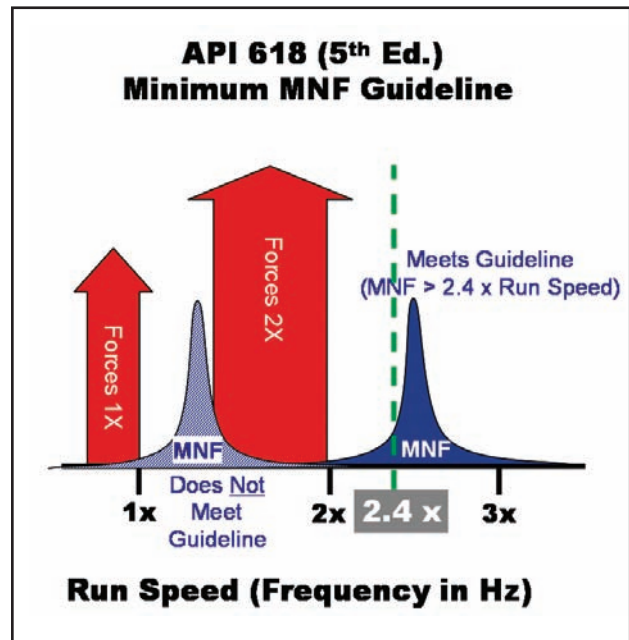

■ Figure 2: Move MNF above 2.4 x run speed to avoid resonance.

Minimum MNF for Compressor System (based on different run speeds)		
Maximum Run Speed (rpm)	Minimum MNF Guideline (Hz)	Minimum MNF Guideline
900	15	36 Hz
1200	20	48 Hz
1800	30	72 Hz

■ Table 1.

der stretch forces. These modes must meet the ±20% separation margin criteria, or a compressor mechanical model analysis should be conducted.

It may be very difficult to meet the ±20% separation margin criterion in some cases, such as variable speed compressors. The cylinder stretch forces are constant for each order of compressor speed, that is, the forces have a fixed amplitude over a wide frequency range. A compressor mechanical model analysis is required in these cases. A risk analysis can be done in the bid stage to identify when these studies are likely required.

Mechanical Design Tips

Fabrication practices such as installation and mounting details to the skid are very important to provide the required stiffness of scrubbers and other components. Skid drawings and mounted details must be available at the time of the mechanical analysis.

As vessel design (length vs. diameter) vs. mounting design can dramatically affect MNFs, vessel fabrication drawings must also be available at this time.

Accurate Finite Element Analysis (FEA) modeling techniques that closely match the real MNFs must be used. Shortcuts in modeling create high risk — see “Factors Affecting Accuracy of Vibration Analysis,” below. Modeling techniques must be field verified.

In some cases, it may be impractical to reach these high frequencies. Inter-tuning can be an option if approved by the owner and packager².

Early involvement between the packager and vibration consultant is highly recommended to discuss mechanical

Compressor Component (example only)	Typical MNF (standard configurations)	Run Speed That May Violate API 618 Separation Margin Guideline	Cost/Design Implications if MNFs Must be Moved Higher
Scrubbers	15 to 30 Hz	> 375 to 750 rpm	Extra costs to add braces or change scrubber design
Cylinders	30 to 50 Hz	> 750 to 1250 rpm	Potential need for outboard supports
Bottles	40 to 70 Hz	> 1000 to 1750 rpm	Bottle supports may be necessary
Piping System	40 to 90 Hz	> 1000 rpm	Pipe braces or pipe layout changes may be necessary

■ Table 2.

design options. This involves input from the owner on the amount of vibration risk that is acceptable and avoids costly changes later.

Factors Affecting Accuracy of Vibration Analysis

API 618 5th Edition gives some general direction for performing simulations and modeling. However, accurate analysis requires that specific details and techniques be used. Different levels of quality exist in the industry (buyer beware). Following, are four key areas that affect accuracy:

Pulsation Analysis — Numerous technical articles document that Time Domain (TD) algorithms provide superior accuracy over the older Frequency Domain (FD) algorithms. In addition to better accuracy, TD algorithms can calculate both static and dynamic pressure drop. This is necessary to assess overall pressure drop and performance throughout the system. FD algorithms are not able to calculate dynamic pressure drop. Dynamic pressure drop calculations are a requirement of API 618 5th Edition.

Scrubber MNF Calculations — FEA is required in DA3 studies to determine the MNFs for each component in the system. For scrubbers, the most important factor in the FEA model is the boundary condition assumption between the scrubber and the skid. Figure 3 illustrates the details needed for accurate analysis (mounting plate, bolts, beams and local skid construction).

Simplistic FEA models will assume a rigid scrubber base or generic estimate of stiffness. Beware of models with “rigid support” or “anchor” or “assumed stiffness.” These have proven to be inaccurate and are to be avoided. Case studies are available illustrating that over 15% error is associated with simplistic models. High error can mean high vibration and failures, or excessive costs (conservative mechanical design).

Compressor Stiffness Assumptions — Because of high gas forces, the compressor frame cannot be considered a rigid body for dynamic studies, even when mounted on concrete. Accurate stiffness assumptions are required when modeling the compressor MNFs (DA3, Step 3a) and forced response analysis of the compressor and bottles (Step 3b1). For superior accuracy, Beta has developed a “super element model” of the compressor frame, which is included in the FEA analysis of the system (see Figure 4). The improved accuracy can reduce the need for costly mechanical supports and braces⁴.

Pulsation Bottle Nozzle Flexibility — Pulsation bottle MNF depends on nozzle connection flexibility (see Figure 5). All mechanical models must employ 3-D FEA techniques to calculate shell flexibility accurately. Simplified assumptions are not valid.

Confusion in Quoting DA3 Studies

As discussed in Part I of this series, the DA3 may require a forced response analysis if the results of the pulsation analysis and the mechanical analysis (MNF modeling) do not meet guidelines. This creates confusion in the quotation phase, because it is uncertain if the forced response analysis will be required and what the associated cost will be of these contingencies. Also, the scope of the forced response study may not be apparent during the quotation phase. Depending on the situation, the scope of the study, or studies, could be small, or quite large. There are two possible forced response studies to consider.

Compressor Mechanical Model Forced Response Study — (Step 3b1) is typically required for medium- to high-speed units when: hp/cylinder >750, or rod loads exceed 80% rated rod load, wide speed range operation is required (more than 25% of rated), compression ratio is below 1.7, or there are critical applications (remote location, high availability required).

Piping System Forced Response Study (Step 3b2):

This analysis is seldom required for standard compressor packages for the following two reasons: the pulsation de-

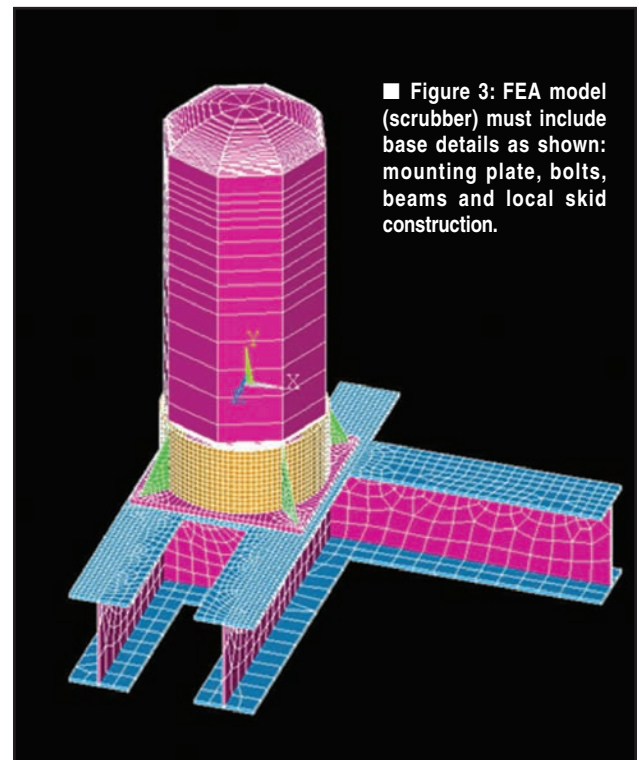

■ Figure 3: FEA model (scrubber) must include base details as shown: mounting plate, bolts, beams and local skid construction.

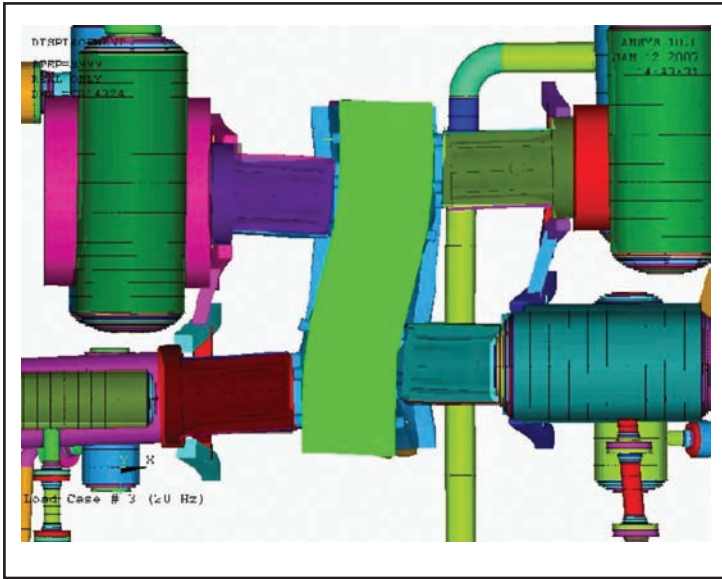

■ Figure 4: Don't assume frames are rigid. This FEA model of a compressor frame illustrates (exaggerated) local flexibility.

sign will typically reduce pulsation forces to low levels; and the mechanical analysis will avoid resonance at the first and second order of compressor speed where the highest pulsation energy typically occurs.

For nonstandard packages, this analysis may be required if the owner is optimizing the system design. For example, determining optimum bottle sizes for multi-unit projects where trade-offs must be made in the design of the piping support and long-term operating costs, or reduced production from high-pressure drop. Trade-offs in the pipe support and pipe layout design around coolers are required to meet the MNF guidelines and thermal expansion (nozzle load) guidelines. Another example is a project involving an existing facility where making changes to meet the Standard's updated guidelines is costly (construction costs, lost production).

Summary

Specifications to Ensure an Effective Pulsation and Vibration Study—

The following specifications will ensure accurate pulsation and vibration analysis, improved reliability (for owners), less warranty costs (for packagers), and a level playing field when quoting on projects (for vibration consultants).

Define scope of the pulsation and vibration study (per API 618 Standard, 5th Edition).

Include TD and FD simulations in the pulsation analysis. The report must contain dynamic pressure drop and TD plots of key forces and pressure pulsations (for all conditions and all frequencies under 150 Hz).

Ensure finite element models include mounting details, including beams, mounting plates and localized skid design, and the report is to include plots of the FEA models employed.

Report the calculated cylinder stretch forces and mode shapes of the pulsation bottles and piping.

Determine the appropriate compressor stiffness assumption based on field-proven results or detailed computer simulations. Mechanical models shall *not* assume the compressor frame is a rigid support. A comprehensive review of the compressor skid and foundation design must be conducted by experienced analysts to assess the design and determine if skid and foundation analysis is required.

Employ 3-D FEA analysis in mechanical models of pulsation bottles to calculate shell flexibility.

Include cylinder stretch forces and vibration assessment in DA3 studies.

Option: for projects requiring high accuracy, the mechanical analysis should include the compressor frame in the mechanical model.

Tips

Given the confusion on forced response studies, we recommend the following three tips for obtaining DA3 study quotations from vibration consultants:

Obtain a firm quote on DA3, Step 3a. Compare suppliers based on this price.

Determine likelihood of forced response analysis Step 3b (1 and 2). Supply optional prices for these studies if required.

Complete a Risk Rating Assessment³ for the compressor. This is a good practice for defining the risk parameters with the unit.

Early involvement between the packager and vibration consultant is recommended to discuss pulsation and mechanical design options (early in the project avoids costly changes for the owner later).

Footnotes

¹ Refer to technical article: Cylinder Stretch as a Source of Vibration in Reciprocating Compressors, 1991, available as a free download from www.betamachinery.com > Support > Articles.

² For more details, see Beta's Application Note 3, How to Avoid Scrubber Vibration, available as a free download from www.betamachinery.com > Support > Application Notes.

³ Find Beta's Risk Rating Chart on www.betamachinery.com > Support > Risk Rating Chart and Specification Guide.

⁴ For more details, refer to Beta's Application Note 5, Compressor Frame Model Increases Accuracy in Mechanical Analysis, available as a free download from its website www.betamachinery.com > Support > Application Notes.

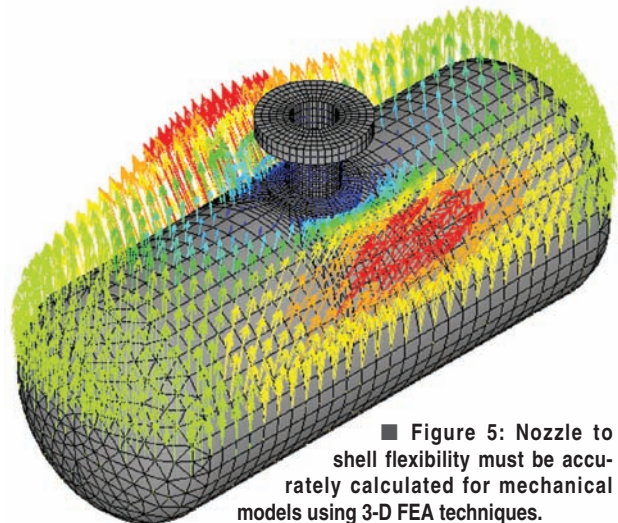

■ Figure 5: Nozzle to shell flexibility must be accurately calculated for mechanical models using 3-D FEA techniques.

Recommendations for Reducing Compressor Total Life Cost and Improving System Performance

The 5th Edition of API 618 (the Standard) was officially released in December 2007. The Standard specifies the minimum design requirements. It does however, encourage compressor designs to be more energy efficient. The updated 5th Edition recommends innovative approaches "should be aggres-

sively pursued by the manufacturer [packager] and end user [owner/operator]" during the compressor design and operation to reduce the total life costs and increase energy conservation.

Improving efficiency and reducing the total life cost can be accomplished through different points of view. Three areas that can result in significant savings are:

1. Pulsation control devices introduce pressure drop into the system. Design modifications that result in lower "total pressure drop" through the system can realize a significant financial reward. Reducing pressure drop results in increased capacity, or reduced fuel costs. Increased capacity generates millions of dollars (per year) in incremental throughput. Fuel savings can generate hundreds of thousands of dollars per year in savings.

2. Overly conservative pulsation control solutions may result in higher manufacturing cost for the packager/owner. For example, Beta Machinery Analysis (Beta) recently saved a packager over US \$100,000 in manufacturing costs by optimizing the pulsation bottle design. An overly conservative design can have significant cost penalties. When a project includes multiple compressors, the cost penalty of a "conservative design" is multiplied, and directly affects overall capital costs and the packager's profit.

3. Over the life of a compressor, the field infrastructure may change the operating parameters of the unit (beyond those anticipated during the initial design). This represents an opportunity to revisit the system design and optimize it where possible. Evaluating the system performance at current and future operating parameters will identify areas to improve capacity, reduce fuel costs, and assess the effectiveness of existing pulsation control devices. Depending on the original design and the degree to which the field parameters have changed, hundreds of thousands of dollars per year can be saved, even after factoring in the cost of modifying the system.

We term these points of view as "optimized design" efforts, as some additional design work is required to determine the optimized solution. The payoff easily justifies the additional design work.

The first step in optimizing a compressor design is to evaluate the "system performance." Once the system performance is understood, opportunities for optimization can be investigated.

How to Assess Design Optimization Opportunities —

System performance includes capacity, efficiency, load (e.g., hp or kWh), total pressure drop, and pulsations for all intended operating conditions. As shown in Figure 6, the "system" starts with the compressor inlet piping and includes the compressor, piping, vessels, pulsation bottles, orifice plates, scrubbers and coolers. The system typically ends where the discharge piping exits the skid.

The system performance model is available once the proposed compressor design and pulsation solution are complete (see Figure 2). The model is used to compare different alternatives and assess the improvement in financial and technical terms.

The system performance model, and subsequent optimization efforts, are based on accurate static plus dynamic pressure drop results for each operating condition.

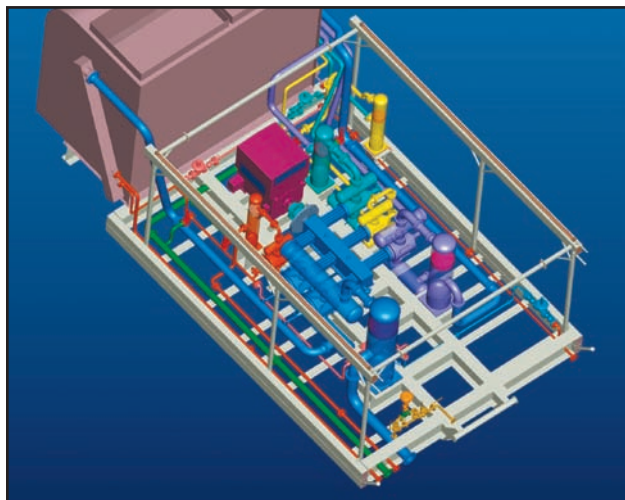

Illustration courtesy of Exterran.

■ **Figure 6: System performance includes all piping, vessels, cooler and pulsation bottles (typically skid edge to skid edge).**

This information is provided by the pulsation analysis. Note that the pulsation analysis must employ proven Time Domain algorithms to obtain accurate total pressure drop results. Older-style pulsation analysis based on Frequency Domain algorithms do not accurately model dynamic pressure drop and are not recommended for system performance analysis.

To optimize the compressor package, the recommended approach is to first develop the baseline system performance model. The baseline compressor design can be modified and optimized until a viable solution is found (Figure 7). The pulsation software is rerun to identify the impact of pressure drop and performance. A simple financial analysis of the incremental improvements (capacity and operating costs) is compared to the required capital costs. This involves teamwork between the owner, packager and pulsation consultant early in the process.

This iterative design process can now be done very quickly with new software tools. Beta's DataMiner is a software tool that distills vast amounts of system data down to the key results. For example, a typical system model often contains millions of data points comprised of permutations in operating conditions, performance results, dynamic forces and pressures. DataMiner efficiently summarizes the key performance data — saving days of manpower to process and evaluate the data.

System Performance Model can Avoid Unpleasant Surprises — The following two examples illustrate the impor-

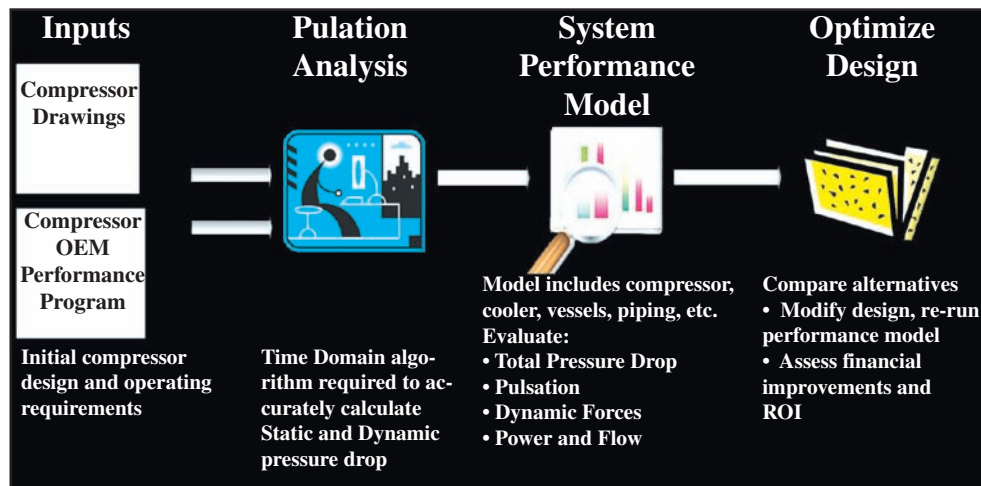

■ **Figure 7: System performance model enables design optimization.**

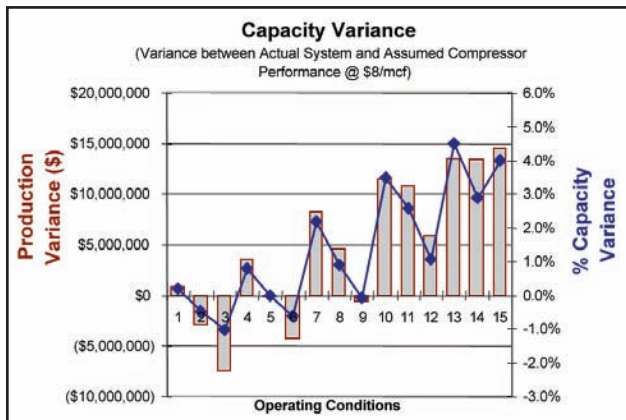

■ Figure 8: System performance provides the most accurate picture of overall compressor design characteristics. Example is based on actual compressor installation (six-throw, one-stage compressor, 4000 hp [2983 kW], 105 to 245 Mmscfd [3.0×10^6 to 6.9×10^6 m³/d]).

tance of calculating and evaluating system performance models. In each case, the owner expected the compressor to deliver the required capacity based on assumptions used in the OEM performance program. However, the actual system per-

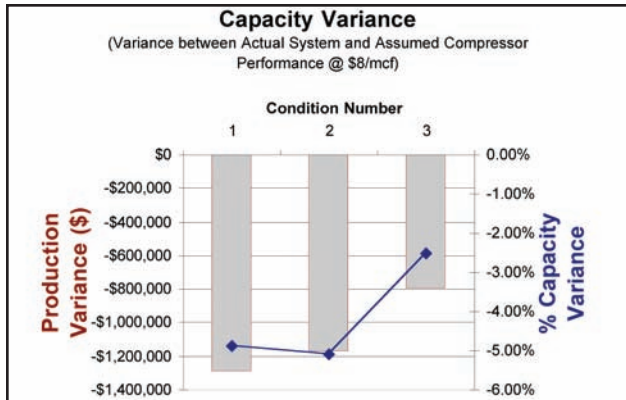

■ Figure 9: Actual system performance variance compared to planned performance (based on initial OEM performance runs, 1600 hp [1193 kW], 1200 rpm, four-throw, three-stage, 7 to 10 Mmscfd [198,100 to 283,169 m³/d], three operating conditions).

formance is not known until the pulsation solution and final piping configuration is defined. Once the final configuration is defined, total pressure drop through the pulsation control devices, piping, coolers, scrubbers, etc., can be determined for each condition. The compressor performance is then re-evaluated using total system pressure drop for each condition

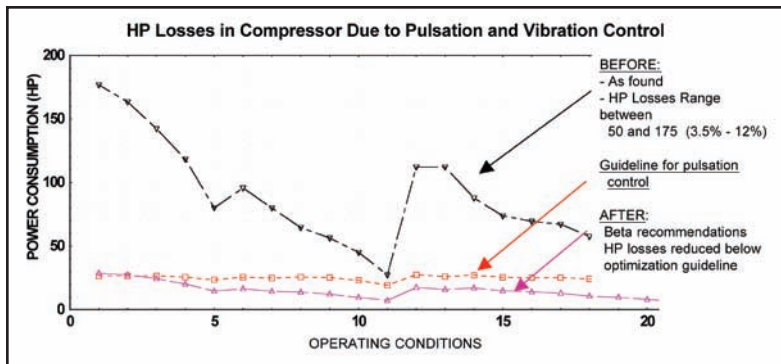

■ Figure 10: Horsepower losses, caused by pressure drop through pulsation control devices, per condition (before and after).

(rather than assumed values used in the OEM program). In each case the variance between actual system performance and “assumed” performance varies by up to 5% (depending upon the specific operating condition as shown by the blue line in Figures 8 and 9). This variance can have a significant impact on the owner’s business plan.

In the first example, for a 4000 hp (2983 kW) unit (single stage), the actual system performance is over US \$10 million/yr higher than originally estimated (for conditions 10, 11, 13, 14 and 15). Figure 8 illustrates the variance percent and production value. Incidentally, the variance in fuel gas consumption varies by more than \$160,000 per year.

The second example is a much smaller unit, 1600 hp (1193 kW), but in this case the actual system capacity is well below the assumed performance. The negative variance is over \$1 million per year for conditions 1 and 2.

These two examples illustrate that variance can be either positive or negative. They also illustrate the importance of an accurate system performance model to avoid unpleasant surprises.

The final system performance model will provide a more accurate summary of the expected fuel costs, capacity, load and other performance data. Operations staff, compressor monitoring services, pipeline flow models and in-house engineering software packages can all benefit from having access to more accurate performance models.

Optimization Yields Significant Payback — The following three examples illustrate the financial benefits (improved cash flow) achieved through optimized compressor designs.

1. Optimized design increases capacity by over \$3 million/yr!. A 1400 hp (1044 kW) reciprocating compressor in a gas gathering application was designed for a variety of operating conditions including flow rates between 7.0 and 19 Mmscfd (198,100 and 537,700 m³/d).

During a field review, Beta identified 21 operating conditions to address various suction and discharge pressures and compressor settings and found that the unit was experiencing high power losses. The unit was designed with a basic pulsation control solution. By reviewing the system performance and pressure losses, Beta identified that between 90 and 150 hp (67 and 112 kW) was wasted through an inefficient design. The analysis further indicated that the losses would prevent the unit from achieving maximum capacity — a key requirement for the owner.

Through a collaborative approach, an optimized pulsation analysis of the existing system established an alternate approach to controlling pulsations, which introduced significantly less pressure drop. With the improved design the losses were reduced significantly for key operating conditions, as shown in Figure 10.

The owner was able to gain significant power by reconfiguring the vessels. The table in Figure 11 outlines the power savings for the key operating conditions. The annual savings in fuel gas through the improvement is estimated at \$75,000 per year — a reasonable gain.

The more interesting result is that the unit can deliver an additional 1.0 to 2.0 Mmscfd (28,300 to 56,600 m³/d) of throughput. Based on the customer’s pricing situation, this translates to over \$3 million of incremental production.

2. Optimization reduces cost of compressor package². During a recent project, an initial pulsation solution recommended conservatively sized bottles for a six-throw, three-stage compressor. Beta evaluated the system performance model and determined an alternative pulsation control solution involving smaller pulsation bottles. See Figure 12. Smaller bottles were found

Operating Condition #	1	2	3	4	12	13
HP Savings	150	137	118	100	95	100
HP/Q Ratio	72	75	83	92	92	92
Incremental Q (Capacity in MMscfd)	2.08	1.83	1.42	1.09	1.03	1.09
Incremental Revenue (Annual — in Millions)	\$6.1	\$5.3	\$4.2	\$3.2	\$3.0	\$3.2

Figure 11: Horsepower savings for key operating conditions.

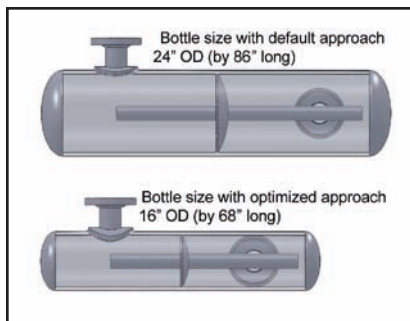

Figure 12: Optimized pulsation bottles saved over US\$100,000 for packager.

to be acceptable for both pulsation and pressure drop criteria. The smaller bottle generated over \$100,000 in savings, based on: two identical units in the project; and each unit realized \$20,000 reduction in bottle costs, \$20,000 reduction in skid costs (small bottles had a significant impact on the skid design), and approximately \$20,000 reduction in factory overhead.

Many new compressors would benefit from an optimized design. For each unit, the hidden capital cost per unit could easily range from \$100,000 per year to well over \$1,000,000 per year in additional capacity.

3. Existing unit benefits by reassessing system performance. The operating parameters for two gas compressors located offshore had changed significantly since the units were originally installed. Recognizing that the changes were potentially significant, the owner of the units commissioned a system capacity audit to determine the maximum capacity that could be obtained under the new operating conditions.

Typically the units are assessed using OEM performance software and assumed pressure drops (usually a percentage of line pressure) to estimate maximum capacity for the new operating parameters. However, as shown in Figure 13, the system performance is more accurate using Beta's Time Domain pulsation models to calculate the total system pressure drop for all operating conditions. In this case, the calculated capacity using total system pressure drop was between 5 and 7.5% lower than calculated using typical pressure drop assumptions. This negative variance had a significant influence on the end user, and prompted an optimization of the design.

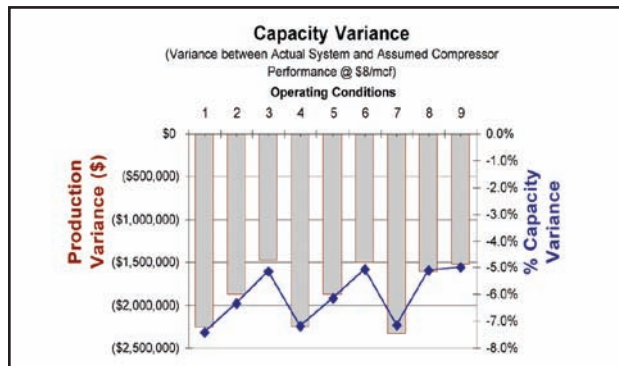

Figure 13: Estimated system pressure drop over predicts capacity.

Beta identified several modifications that could reduce total pressure drop without adversely affecting the pulsation and pulsation-induced unbalanced force levels in the installation. In addition, we identified improvements that could be made in the engine and restaging of the unit. Figure 14 illustrates the cash flow impact from four of the improvements. The combination of these four recommendations generates an incremental cash flow of \$3.5 million dollars per year (based on \$8/mcf). Using this information, the end user can assess the capital cost and payout from the proposed modifications.

Overcoming Barriers to Improved Compressor Design

Given the improved profitability and fast payback, why isn't every compressor being optimized? Here are some reasons: many compressor transactions are focused on initial capital costs only; annual operating costs, including fuel or electrical energy may not be included in purchase decision; fast delivery is critical to the buyer. Penalties may exist when manufacturing delays occur. Therefore the parties may hesitate to consider changes to the initial design; the owner/operator is not aware of the "hidden" opportunity costs associated with an optimized design. Hidden costs may include performance effects, excessive pressure drop or excessive material costs.

Overcoming these barriers starts with the owner specifying a design optimization review. The review occurs concurrently with the pulsation analysis and initial compressor layout.

		Change in Flow (mmcf/d)						
Suction-Discharge	a. Modify Cylinder Nozzle Orifice	b. 10% Increase in Cooler ID	c. Convert to 3 Stage (Eliminate 4th Stage)	d. Engine Adjustment (Add 85 BHP)	e. (C)NO, Cooler	f. (C)NO, Cooler, 3 Stage	g. (C)NO, Cooler, 3 Stage, Engine	
45-700	0.19	0.25	0.65	0.34	0.35	0.87	1.21	
45-900	0.1	0.18	0.47	0.3	0.3	0.63	0.93	

		Increased Cash Flow (\$/year) - assuming \$8/mcf						
Suction-Discharge	a. Cylinder Nozzle Orifice	b. 10% Increase in Cooler ID	c. Convert to 3 Stage (Eliminate 4th Stage)	d. Engine Adjustment (Add 85 BHP)	e. (C)NO, Cooler	f. (C)NO, Cooler, 3 Stage	g. (C)NO, Cooler, 3 Stage, Engine	
45-700	\$64,800	\$73,000	\$1,288,000	\$92,800	\$1,022,000	\$2,540,400	\$3,533,200	
45-900	\$292,000	\$525,600	\$1,127,400	\$876,000	\$876,000	\$1,828,800	\$2,715,600	

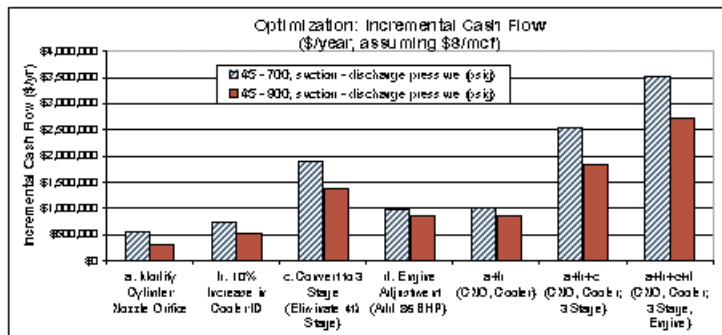

Figure 14: Reducing total system pressure drop increases capacity.

When initiated at the bid stage, and conducted efficiently, the review will have negligible impact on the overall production schedule, ensuring fast delivery of the compressor.

With the new software tools described in this article, optimization can be completed efficiently without creating costly delays in the project. Owners and packagers can quickly review the results and make intelligent decisions that improve overall project economics.

Summary

API 618 (5th edition) outlines minimum design requirements. Owners and packagers are encouraged to include efficiency and total life costs into their designs.

It is up to the end user (owner/operator) or packager to specify optimization requirements. An optimized design will not happen otherwise.

A system performance model is a valuable tool to confirm the compressor package will meet the intended capacity requirements for required operating conditions.

Software tools are now available to enable rapid optimization. Beta's DataMine is an example of one of the tools that allows the consultant to find the best solution quickly and efficiently. The incremental study cost is minor, while the upside value is significant.

Optimization works best when the end user, packager, and pulsation consultant meet and collaborate early in the process to discuss optimization criteria and options and agree on the final design.

System performance and optimization require accurate estimates of total pressure drop. This is only accomplished by pulsation analysis based on Time Domain algorithms.

Also, it is up to the end user to identify when existing equipment may be operating outside the original operating parameters. These changes may introduce additional pressure drop and create likely candidates for system performance optimization opportunities. ■